

PACSystems™ RX3i

16-CHANNEL ANALOG CURRENT INPUT MODULE (IC694ALG233)



Warning Notes as Used in this Publication



Warning

Warning notices are used in this publication to emphasize that hazardous voltages, currents, temperatures, or other conditions that could cause personal injury to exist in this equipment or may be associated with its use.

In situations where inattention could cause either personal injury or damage to equipment, a Warning notice is used.

Notes: Notes merely call attention to information that is especially significant to understanding and operating the equipment.

These instructions do not purport to cover all details or variations in equipment, nor to provide for every possible contingency to be met during installation, operation, and maintenance. The information is supplied for informational purposes only, and Emerson makes no warranty as to the accuracy of the information included herein. Changes, modifications, and/or improvements to equipment and specifications are made periodically and these changes may or may not be reflected herein. It is understood that Emerson may make changes, modifications, or improvements to the equipment referenced herein or to the document itself at any time. This document is intended for trained personnel familiar with the Emerson products referenced herein.

Emerson may have patents or pending patent applications covering subject matter in this document. The furnishing of this document does not provide any license whatsoever to any of these patents.

Emerson provides the following document and the information included therein as-is and without warranty of any kind, expressed or implied, including but not limited to any implied statutory warranty of merchantability or fitness for particular purpose.

Introduction

The PACSystems RX3i 16-Channel Analog Current Input module provides 16 single-ended input channels. Each input can be configured using the configuration software for any of three input ranges:

- 4 to 20 mA
- 0 to 20 mA
- 4 to 20 mA Enhanced

High and Low alarm limits are available on all ranges. In the 4 to 20 mA Enhanced range, a low alarm limit can be set up to detect input current from 4 mA to 0 mA, providing open-wire fault detection in 4 to 20 mA Enhanced applications.

The module also reports module status and external power supply status to the CPU using its assigned program reference addresses.

This module can be installed in any I/O slot that has a serial connector in an RX3i system.

Module Features

- Completely software-configurable, no module jumpers to set
- Open-circuit detection for all inputs in 4 to 20 mA Enhanced Range
- Configurable scaling and offsets per channel
- High alarm, low alarm, high-high alarm, low-low alarm detection and reporting selectable per channel
- Module fault reporting
- Supports diagnostic point fault contacts in the logic program
- Supports firmware upgrades.
- Positive and negative Rate of Change Alarms
- Display of module serial number, revision and date code in programming software.
- Supports hot insertion/removal

Module Power

This module consumes 120 mA from the 5 VDC bus on the RX3i backplane. It also requires 65 mA plus current loop current(s) from a user-supplied +24 VDC supply.

LEDs

The MODULE OK LED provides module status information as follows:

ON: status is OK, module configured;

OFF: no backplane power or software not running (watchdog timer timed out);

Continuous rapid blinking: configuration data not received from CPU;

Slow blinking, then OFF: failed power-up diagnostics or encountered code execution error.

The USER SUPPLY LED indicates that the external 24 VDC supply is within specifications.

Specifications: ALG233

Specification	Description
Number of Channels	1 to 16 selectable; single-ended
Input Current Ranges	0 to 20 mA, 4 to 20 mA and 4 to 20 mA Enhanced (selectable per channel)
Calibration	Factory calibrated to: 0.5µA per count on 4 to 20 mA range 0.625µA per count on 0 to 20 mA and 4 to 20 mA Enhanced range
Update Rate for All Channels	5ms
Resolution at 0–20 mA	0.625µA/bit
Resolution at 4–20 mA	0.5µA/bit
Resolution at 4–20 mA Enhanced	0.5µA/bit
Absolute Accuracy ^{1, 2}	±0.25% of full scale @ 25°C (77°F) ± 0.5% of full scale over specified operating temperature range
Linearity	< 4 LSB from 4 to 20 mA (4 to 20 mA range) < 4 LSB from 100µA to 20 mA (0 to 20 mA and 4 to 20 mA Enhanced ranges)
Isolation, Field to Backplane (optical) and to frame ground	250VAC continuous; 1500 VAC for 1 minute
Common Mode Voltage	0 volts (single-ended channels)
Cross-Channel Rejection	> 70dB from DC to 1kHz
Input Impedance	250 Ω
Input Low Pass Filter Response	23 Hz
External Supply Voltage Range	20 to 30 VDC
External Supply Voltage Ripple	10%
Power Consumption	120 mA from the +5 VDC bus on the backplane 65 mA from 24 VDC external user power supply (in addition to current loop currents)

¹ In the presence of severe Radiated RF interference (IEC 61000-4-3, 10V/m), accuracy may be degraded to ±5% of full scale.

² In the presence of severe Conducted RF interference (IEC 61000-4-6, 10Vrms), accuracy may be degraded to ±1% of full scale.

Refer to the PACSystems RX3i System Manual GFK-2314, for product standards, general operating specifications, and installation requirements.

Configuration: ALG233

Configurable parameters for the ALG233 module are described below.

Module Settings

Parameter	Choices	Description
Active Channels	1 to 16	The number of channels to be scanned. Channels are scanned in sequential, contiguous order.
Channel Value Reference Address	Valid memory types: %AI (default), %AQ, %R, %W, , Symbolic Memory*	The starting address in memory for input data from the module. * Note: To support Symbolic Memories, the “Variable Mode” property should be enabled in PME.
Channel Value Reference Length	Read-only	Depends on the number of active channels. Each channel provides two words of analog input data to the Controller CPU.

Parameter	Choices	Description
Diagnostic Reference Address	Valid memory types: %I (default), %Q, %G, %M, %T, Symbolic Memory*	Starting address for the channel diagnostics data. Used only when Module Level Diagnostic Reporting is enabled. * Note: To support Symbolic Memories, the "Variable Mode" property should be enabled in PME.
Diagnostic Reference Length	Read-only	The amount of memory required for the channel diagnostics data. When Module Level Diagnostic Reporting is enabled, 32 bits of diagnostic data are allocated for each active channel.
Module Status Reference Address	Valid memory types: %I (default), %Q, %G, %M, %T, Symbolic Memory*	The starting address in memory for status information from the module. * Note: To support Symbolic Memories, the "Variable Mode" property should be enabled in PME.
Module Status Reference Length	0, 32	The number of module status bits reported to the CPU. Data format is shown below. When set to 0, status reporting is disabled. To enable status reporting, set this parameter to a value other than 0.
I/O Scan Set	1 through 32	Assigns the module to an I/O Scan Set defined in the CPU configuration.
Inputs Default	Force Off (default) or Hold Last State	In the event of module failure or removal, this parameter specifies the state of all Channel Value References for the module. Force Off = Channel Values clear to 0. Hold Last State = Channels hold their last state.
Module Level Diagnostic Reporting	Disabled (default) or Enabled	If enabled, 32 bits of data are allocated for each active channel. Diagnostic Reporting and Fault Reporting can be enabled separately for each channel.

Module Status Format

Bit	Description
0	0: Module has failed or is not present 1: Module OK
1	Reserved
2	0: Field power not present 1: Field power present
3 through 31	Reserved

Channel Data

Parameter	Choices	Description
Range	4-20 mA (default), 0-20 mA, or 4-20 mA + (enhanced)	In the 4-20 mA range, input currents from 4 to 20 mA are reported to the CPU as values from 0 to 32000 units. In the 0 to 20 mA range, input currents from 0 to 20 mA are reported to the CPU as values from 0 to 3200 units. In the 4 to 20 mA enhanced range, currents from 4 to 20 mA are reported to the CPU as values from 0 to 32000 units. Currents below 4 mA are reported as negative values with 0 represented as – 8000 units.
Channel Value Format	32 Bit Floating Point (default) or 16 Bit Integer	32 Bit Floating Point: A real value, range 3.40282e+38 through 3.40282e+38 16 Bit Integer: The low word of the 32-bit channel data contains the 16-bit integer channel value. The high word contains the sign of the 16-bit integer. If the 16-bit integer result is negative, the upper word in the 32-bit channel data is set to 0xFFFF. If the 16-bit integer result is positive, the upper word is set to 0x0000. When the Channel Value Format parameter is set to 16 Bit Integer, 1000 Eng Units are equal to 1.0 A/D Unit.
High Scale Value (Eng Units)	The defaults and ranges for the four scaling parameters depend on the configured Range Type and Channel Value Format.	Scaling is disabled if: High Scale Eng. Units = High Scale A/D Units and Low Scale Eng. Units = Low Scale A/D Units. Default is High A/D Limit of selected range type. When Channel Value Format is set to 32 Bit Floating Point, range is - 3.40282e+38 through 3.40282e+38. When set to 16 Bit Integer, range -32,768 through +32,767.
Low Scale Value (Eng Units)		
High Scale Value (A/D Units)		
Low Scale Value (A/D Units)		
Positive Rate of Change Limit (Eng Units/Second)	Range: 0.0 (default) through 3.40282e+38	Rate of change in Engineering Units per Second that will trigger a Positive Rate of Change alarm. If set to 0, limit is disabled. Used with “Rate of Change Sampling Rate” parameter.
Negative Rate of Change Limit (Eng Units/Second)	Range: 0.0 (default) through 3.40282e+38	Rate of change in Engineering Units per Second that will trigger a Negative Rate of Change alarm. If set to 0, limit is disabled. Used with “Rate of Change Sampling Rate” parameter.
Rate of Change Sampling Rate (ms)	60.0 (default) through 300000.0	Time from 60 through 300000ms to wait between comparisons. If set to the default value of 60.0, the module checks after every input sample.
High-High Alarm (Eng Units)	The defaults and ranges for these parameters depend on the configured Range and Channel Value Format.	Alarms and Deadbands All the alarm parameters are specified in Engineering Units. To use alarming, Diagnostic Reporting or Fault Reporting must be enabled. High-High Alarm and Low-Low Alarm: When the configured value is reached or passed, a Low-Low Alarm or High-High Alarm is triggered. The configured values must be lower than/higher than the corresponding low/high alarm limits. High Alarm and Low Alarm: When the configured value is reached or below (above), a Low (High) Alarm is triggered. High and Low Alarm Deadbands: A range in Engineering Units above the alarm condition (low deadband) or below the alarm condition (high deadband) where the alarm status bit can remain set even after the alarm condition goes away. For the alarm status to clear, the channel input must
High Alarm (Eng Units)		
Low Alarm (Eng Units)		
Low-Low Alarm (Eng Units)		

Parameter	Choices	Description
High-High Alarm Deadband (Eng Units)		fall outside the deadband range. Alarm Deadbands should not cause the alarm clear condition to be outside the Engineering Unit User Limits range. For example, if the engineering unit range for a channel is -1000.0 to +1000.0 and a High Alarm is set at +100.0, the High Alarm Deadband value range is 0.0 to less than 1100.0. A deadband of 1100.0 or more would put the High Alarm clear condition below -1000.0 units making the alarm impossible to clear within the limits.
High Alarm Deadband (Eng Units)		
Low Alarm Deadband (Eng Units)		
Low-Low Alarm Deadband (Eng Units)		
User Offset	16 Bit Integer range: -32768 through 32768 32 Bit Floating Point, range: -3.40282e+38 through 3.40282e+38. 0.0 (default)	Engineering Units offset to change the base of the input channel. This value is added to the scaled value on the channel prior to alarm checking.
Software Filtering	Disabled (default) or Enabled	Controls whether software filtering will be performed on the inputs.
Integration Time (ms)	0 (default) through 4,294,967,295ms	Specifies the amount of time in milliseconds for the software filter to reach 63.2% of the input value. A value of 0 indicates software filter is disabled. A value of 100 indicates data will achieve 63.2% of its value in 100ms.
Diagnostic Reporting Enable	Disabled (default) or Enabled (Available only if Module Level Diagnostic Reporting is enabled on the Settings tab.)	If Diagnostic Reporting is enabled, the module reports channel alarms in the Diagnostic Reference memory. Channel alarms can be individually enabled.
Fault Reporting Enable		If Fault Reporting is enabled, the module logs a fault log in the I/O Fault table for each occurrence of a channel alarm. Fault reporting for channel alarms can be individually enabled.

Input Scaling

In the 4 to 20 mA range, input data is scaled so that 4 mA corresponds to a count of 0 and 20 mA corresponds to a count of 32000. In the 0 to 20 mA range, 0 mA corresponds to a count of 0 and 20 mA corresponds to a count of 32000. Full 16-bit resolution is available over the 4 to 20 mA and 0 to 20 mA ranges.

4 to 20 mA Enhanced range can also be configured. In that range, 0 mA corresponds to a count of -8000, 4 mA corresponds to a count of 0 (zero) and 20 mA corresponds to a count of +32000. A low alarm limit can be set up to detect input current from 4 mA to 0 mA, providing open wire fault detection in 4 to 20 mA applications.

Analog values are scaled over the range of the converter. Factory calibration adjusts the analog value per bit (resolution) to a multiple of full scale (0.625 μ A/bit in 0-20mA range; 0.5 μ A/bit in other ranges). This calibration leaves a normal 16-bit converter with 32000 counts. The data is scaled with the 32000 counts over the analog range. The data is scaled as shown below.

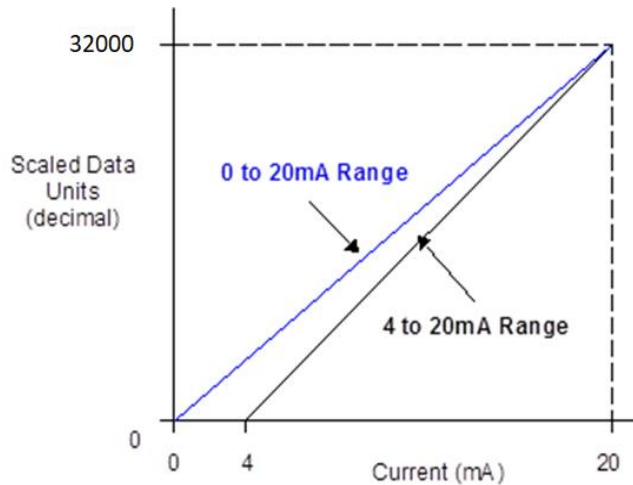

Rate of Change Alarms

The ALG233 can detect both Negative Rate of Change and Positive Rate of Change in Engineering Units per Second. When either of the Rate of Change parameters is configured to be non-zero, the module takes the difference in Engineering Units between the previous sample and the current sample, then divides by the elapsed time between samples.

If the Engineering Unit change from the previous sample to current sample is negative, the module compares the rate change with the Negative Rate of Change parameter.

If the Engineering Unit change between samples is positive, the module compares the rate change with the Positive Rate of Change parameter value.

In either case, if the rate of change is greater than the configured rate, a rate of change alarm occurs. The actions taken by the module following the alarm depend on the enabled rate of change actions that have been set up in the Diagnostic Reporting Enable and Fault Reporting Enable parameters.

The Rate of Change Sampling Rate parameter determines how frequently the module compares the Rate of Change. The minimum value which can be used with this parameter is 60ms i.e., the module can compare the rate of change after every 60ms.

When the CPU transitions to RUN mode or the module field power is cycled, the ALG233 waits 100ms before starting Rate of Change detection. This is to ignore any glitches in the input signal.

Channel Input Data

The module reports its channel input data in its configured input words, beginning at its assigned Channel Value Reference Address. Each channel occupies 2 words, whether the channel is used: Depending on its configured Channel Value Format, each enabled channel reports a 32-bit floating point or 16-bit integer value to the CPU.

In the 16-bit integer mode, the low word of the 32-bit channel data area contains the 16-bit integer channel value. The high word (upper 16-bits) of the 32-bit value is set with the sign extension of the 16-bit integer. This sign-extended upper word allows the 16-bit integer to be read as a 32-bit integer type in logic without losing the sign of the integer. If the 16-bit integer result is negative, the upper word in the 32-bit channel data has the value 0xFFFF. If the 16-bit integer result is positive, the upper word is 0x0000.

The 16-bit resolution module analog input data is stored in the CPU in 16-bit 2's complement format as shown below.

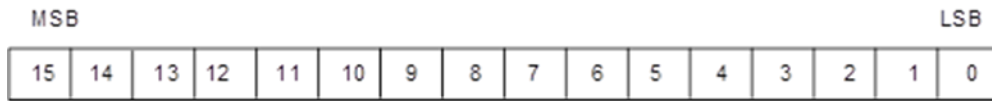

Channel Diagnostic Data

In addition to the input data from field devices, the module can be configured to report channel diagnostics status data to the CPU. The CPU stores this data at the Diagnostic Reference Address configured for the module. Use of this feature is optional.

The diagnostics data for each channel occupies 2 words (whether the channel is used or not):

When a diagnostic bit equals 1, the alarm or fault condition is present on the channel. When a bit equals 0 the alarm or fault condition is either not present or detection is not enabled in the configuration for that channel.

For each channel, the format of this data is:

Bit	Description
0	1 = Low Alarm Fault
1	1 = High Alarm Fault
2	1 = Under Range Detected
3	1 = Over Range Detected
4	1 = Open Wire Fault
5 – 15	Reserved (set to 0)
16	1 = Low-Low Alarm Fault
17	1 = High-High Alarm Fault
18	1 = Negative Rate of Change Alarm
19	1 = Positive Rate of Change Alarm
20 - 31	Reserved (set to 0)

Field Wiring: ALG233

Terminal	Connection
1	User supplied 24V Input; provides loop power via 24VOUT terminal (pin 2)
2	+24V loop power tie point
3	Current Input, Channel 1
4	Current Input, Channel 2
5	Current Input, Channel 3
6	Current Input, Channel 4
7	Current Input, Channel 5
8	Current Input, Channel 6
9	Current Input, Channel 7
10	Current Input, Channel 8
11	Current Input, Channel 9
12	Current Input, Channel 10
13	Current Input, Channel 11
14	Current Input, Channel 12
15	Current Input, Channel 13
16	Current Input, Channel 14
17	Current Input, Channel 15
18	Current Input, Channel 16
19	Common connection to input current sense resistors; user supplied 24V input return or 24VIN return
20	Frame ground connections for cable shields

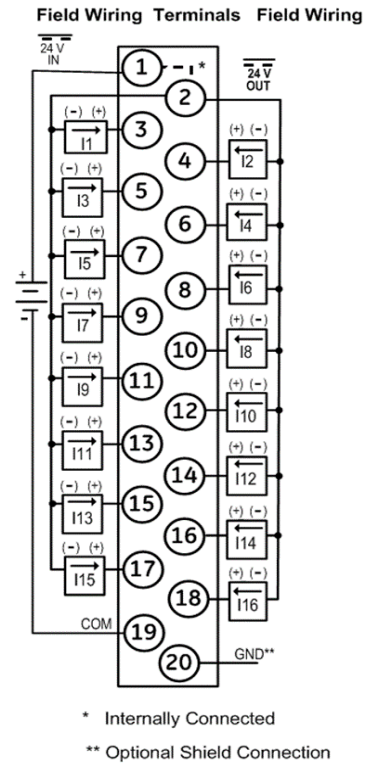

Connection Example 1

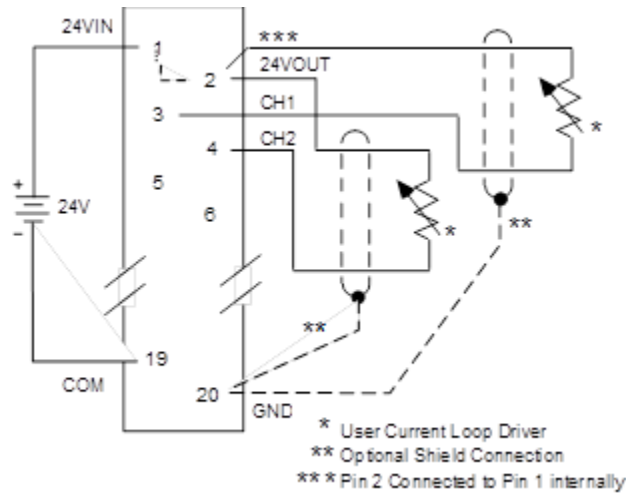

Connection Example 2

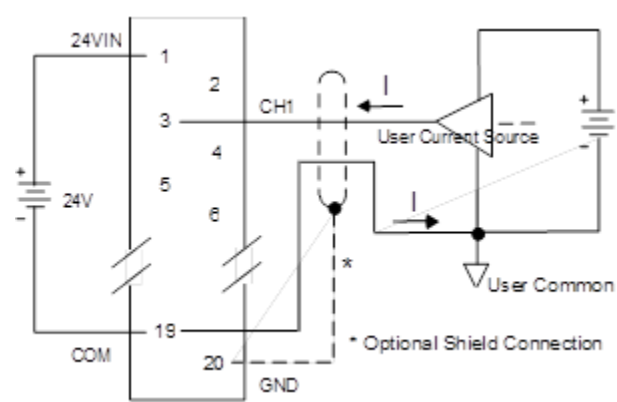

To limit common-mode voltages, the current source can be tied to the COM terminal if the source is floating.

Release History

Version	Firmware Release	Date	Description
IC694ALG233-DC	2.00	Dec 2020	This release addresses the module hardware obsolescence. Note 2 which specifies the accuracy in the presence of conducted RF interference is corrected (+/- 0.5% changed to +/- 1%).
IC694ALG233-CB	1.60	Sep 2019	Following Emerson's acquisition of this product, changes have been made to apply appropriate branding and registration of the product with required certification agencies. No changes to material, process, form, fit or functionality.
IC694ALG233-BB	1.60	Nov 2015	Documentation change only. Removed %AI, %AQ, %R, %W from the Diagnostic Reference Address and Module Status Reference Address module parameters.
IC694ALG233-BB	1.60	May 2012	Resolves several rarely occurring issues that were identified in field and factory testing.
IC694ALG233-AA	1.00	July 2011	Initial release.

Upgrades

An upgrade kit containing firmware version 2.00, 41G1485-MS10-003-A2, is available for download at <https://www.emerson.com/Industrial-Automation-Controls/support>.

Compatibility

Requirement	Description
Programmer version requirements	PAC Machine Edition version 7.00 SIM 2 or later is required to configure the ALG233 module.
CPU firmware requirements	RX3i CPU firmware version 6.70 or later is required to operate the ALG233 module.
Module firmware upgrade	The module revision IC694ALG233-CB or before cannot be upgraded with the firmware revision 2.00 or later as the firmware is not backward compatible. Similarly, module revision IC694ALG233-DC or later cannot be updated with any firmware revision earlier than 2.00.

Problems Resolved in this Revision

Subject	Description
<p>Loss of I/O fault is logged for analog modules when a Clear All Memory command is sent through the RX3i CPU's serial port.</p>	<p>This release resolves the issue from IC694ALG233-DC, since the firmware is not compatible to revision IC694ALG233-CB or earlier.</p> <p>When the Rx3i CPU has more than three analog modules in a rack, PAC Machine Edition is communicating with serial port and sends a Clear All Memory command, then any module may unexpectedly log a Loss of I/O Module fault.</p> <p>To recover from this issue, power cycle the CPU and download configuration. Or while clearing, do not use Clear All, but select the configuration item checkboxes.</p>

Restrictions and Open Issues

Subject	Description
<p>Loss of I/O fault is logged for analog modules when a Clear All Memory command is sent through the serial port of the RX3i CPU.</p>	<p>This is applicable to revisions IC694ALG233-CB or earlier.</p> <p>When the Rx3i CPU has more than three analog modules in a rack, PAC Machine Edition is communicating with serial port and sends a Clear All Memory command, then any module may unexpectedly log a Loss of I/O Module fault.</p> <p>To recover from this issue, power cycle the CPU and download configuration. Or while clearing, do not use Clear All, but select the configuration item checkboxes.</p>
<p>Constant Sweep Exceeded fault is logged when ALGxxx modules are in different racks, with at least one ALGxxx in a remote rack.</p>	<p>With the CPU in constant sweep mode, if two or more ALG modules are placed in a system such that one ALG module is in a remote expansion rack and the others are in a different rack, as soon the hardware configuration is downloaded, and the CPU is returned to run mode, the CPU logs a fault stating "Constant sweep exceeded" in the Controller fault table.</p>

Operational Notes

Subject	Description
<p>Restrictions on Hot Swap</p>	<p>ALG233 module should not be Hot swapped in any of the Expansion and Remote expansion Rx3i backplane racks. Doing so may damage the module or backplane hardware and disrupt the module operations.</p>

Installation in Hazardous Areas

The following information is for products bearing the UL marking for Hazardous Areas or ATEX marking for explosive atmospheres:

WARNING

- EQUIPMENT LABELED WITH REFERENCE TO CLASS I, GROUPS A, B, C & D, DIV. 2 HAZARDOUS LOCATIONS IS SUITABLE FOR USE IN CLASS I, DIVISION 2, GROUPS A, B, C, D OR NON-HAZARDOUS LOCATIONS ONLY
 - EXPLOSION HAZARD - SUBSTITUTION OF COMPONENTS MAY IMPAIR SUITABILITY FOR CLASS I, DIVISION 2 or ATEX ZONE 2;
 - EXPLOSION HAZARD - WHEN IN HAZARDOUS LOCATIONS, TURN OFF POWER BEFORE REPLACING OR WIRING MODULES; AND
 - EXPLOSION HAZARD - DO NOT CONNECT OR DISCONNECT EQUIPMENT UNLESS POWER HAS BEEN SWITCHED OFF OR THE AREA IS KNOWN TO BE NONHAZARDOUS.
-

ATEX Marking

II 3 G Ex nA IIC T4 X Ta: 0 - 60C

Technical Support & Contact Information

Online Technical Support and Global Care: <https://www.emerson.com/en-us/support>.

Knowledge Base: <https://www.emerson.com/Industrial-Automation-Controls/support>

Home link: <http://www.Emerson.com/Industrial-Automation-Controls>

Note: If the product is purchased through an Authorized Channel Partner, please contact the seller directly for any support.

Emerson reserves the right to modify or improve the designs or specifications of the products mentioned in this manual at any time without notice. Emerson does not assume responsibility for the selection, use or maintenance of any product. Responsibility for proper selection, use and maintenance of any Emerson product remains solely with the purchaser.

© 2019 Emerson. All rights reserved.

Emerson Terms and Conditions of Sale are available upon request. The Emerson logo is a trademark and service mark of Emerson Electric Co. All other marks are the property of their respective owners.

